



PROTECTO WRAP COMPANY

1955 South Cherokee Street

Denver, Colorado 80223

(800)759-9727

www.protectowrap.com

AFM AND AFM-WM ANTI-FRACTURE MEMBRANES AND JIFFY SEAL 140/60 WATERPROOFING MEMBRANES

CSI Section:

09 30 00—Tiling

1.0 RECOGNITION

Protecto Wrap Company’s AFM and AFM-WM Anti-Fracture Membranes and Jiffy Seal 140/60 Waterproofing Membranes recognized in this report have been evaluated for use as Sheet Membranes serving as barriers to positive liquid water migration in load-bearing, bonded, thin-set installations of ceramic tile or, dimension stone on floors, and as shower pan linings. The physical characteristic properties of these membranes comply with the intent of the provisions of the following codes and regulations:

- 2018 and 2015 Uniform Plumbing Code® (UPC)
- 2018 and 2015 International Building Code® (IBC)
- 2018 and 2015 International Residential Code® (IRC)
- 2018 and 2015 International Plumbing Code® (IPC)
- 2019 and 2016 California Building Code (CBC) – attached Supplement
- 2019 and 2016 California Residential Code (CRC) – attached Supplement
- 2019 and 2016 California Plumbing Code (CPC), Title 24, Part 5 – attached Supplement
- 2020 and 2017 City of Los Angeles Building Code (LABC) – attached Supplement
- 2020 and 2017 City of Los Angeles Residential Code (LARC) – attached Supplement
- 2020 Florida Building Code, Building – attached Supplement
- 2020 Florida Building Code, Residential – attached Supplement
- 2020 Florida Building Code, Plumbing – attached Supplement

2.0 LIMITATIONS

AFM, AFM-WM Anti-Fracture Membranes, and Jiffy Seal 140/60 Membranes as noted in this report comply with, or are acceptable alternatives, to what is specified in the codes listed in Section 1.0 of this report, subject to the following conditions:

2.1 AFM, AFM-WM Anti-Fracture Membrane, and Jiffy Seal 140/60 Membrane installations shall comply with the requirements of the code, this report, and Protecto Wrap Company’s installation instructions. Where conflicts occur, the more restrictive shall govern.

2.2 AFM, AFM-WM Anti-Fracture Membrane and Jiffy Seal 140/60 Membrane installations are only allowed to be installed in ceramic tile and dimension stone installations over concrete, plywood, and No. 20 gage [0.036 inch (0.91mm)] galvanized sheet metal floor substrates.

2.3 AFM, AFM-WM Anti-Fracture Membrane and Jiffy Seal 140/60 Membrane installations shall not bridge substrate expansion joints or cracks wider than 3/8 inch (9.5 mm).

2.4 When AFM, AFM-WM Anti-Fracture or Jiffy Seal 140/60 Membranes are used as a shower liner in site-built shower installations, the completed shower shall be leak tested in accordance with the applicable sections of the codes noted in Section 1.0.

2.5 The AFM and AFM-WM Anti-Fracture Membranes and Jiffy Seal 140/60 Membranes recognized in this report are produced by Protecto Wrap Company in Denver, CO.

3.0 PRODUCT USE

3.1 General

3.1.1 AFM and AFM-WM Anti-Fracture Membranes are waterproofing membranes used in interior and exterior installations of ceramic tile and dimension stone on concrete, plywood, and metal floor substrates in compliance with Sections 1209.2 and 2103 of the IBC.

3.1.2 AFM and AFM-WM Anti-Fracture Membranes are waterproofing membranes used as shower linings in accordance with Section 417.5 of the IPC and Section 408.7 of the UPC.

3.2 Installation

The installation of the AFM and AFM WM Anti-Fracture membranes shall comply with this report and the manufacturer’s instructions. Where conflicts occur, the more restrictive shall govern.

3.2.1 AFM Anti-fracture Membrane

3.2.1.1 **Installation over Concrete Substrate:** Concrete surfaces shall be clean and free of all grease, oil, and other contaminants. Surfaces that are dry or dusty shall be swept off and dampened. All voids, cracks, joints, holes, and excessively rough areas in the substrate shall be filled with a

The product described in this Uniform Evaluation Service (UES) Report has been evaluated as an alternative material, design or method of construction in order to satisfy and comply with the intent of the provision of the code, as noted in this report, and for at least equivalence to that prescribed in the code in quality, strength, effectiveness, fire resistance, durability and safety, as applicable, in accordance with IBC Section 104.11. This document shall only be reproduced in its entirety.





smooth cementitious material to achieve a smooth, uniform surface. Membranes shall be installed over concrete surfaces that have cured for at least seven days. Concrete under hydrostatic head or where moisture vapor transmission is expected shall be avoided. Ambient and substrate temperatures shall be between 45°F and 120°F (7°C and 49°C) during application of membranes.

The #6000 water-based primer for interior applications, Universal Water Based Primer for interior and exterior applications or the #80 primer for exterior applications, is applied to the concrete surface using a brush or roller at an application rate of 200 square feet per gallon (4.91 m²/L) and shall be allowed to dry fully before installation of the membrane. When fully cured, the primer will be tacky to the touch and not come off the surface.

After preparation of the substrate, the membrane shall be rolled out and cut to the desired length and the release paper carefully removed from half of the membrane. The membrane shall then be aligned and pressed onto the substrate in its intended location. Remaining release paper shall be removed at one time, exposing the bottom adhesive, while the membrane is smoothed onto the primed surface. Continuous smoothing of the membrane as it meets the primer is required to ensure adhesion and to mitigating the trapping of air under the membrane. If the membrane is misaligned, the rolls shall be cut and restarted. The membrane shall be installed using a minimum overlap of 2 inches (50.8 mm) at the sides and 6 inches (152 mm) at the ends.

Installed membranes shall be inspected immediately after application and all identified defects repaired as follows. If the membrane is damaged or requires repair, the area shall be cleaned and lightly primed with #6000 Primer, Universal Water Based primer, or #80 Primer to 6 inches (152 mm) beyond the damaged area. A membrane patch shall be cut and rolled on firmly to fully contact the surface. A bead of JS160H Mastic shall be troweled on the edges of the patch. Should air become trapped beneath the membrane, the bubble shall be punctured with a sharp instrument and the sheet shall be pressed flat. Full membrane contact is required with the primed substrate.

Flashing around protrusions or metal lip edges shall be installed under the membrane to mitigate water intrusion. All primed surfaces shall be covered with the membrane on the same day that the primer is applied, or they shall be primed again.

At pipes, conduits and any other protrusions through the subfloor, the surfaces shall be primed and taped with a 6-inch (152 mm) piece of AFM 500 Detail Tape. The detail tape shall be formed to fit tightly to the protrusions and to the subfloor. At drain openings, a light coat of #6000 Primer, Universal Water Based Primer, or #80 Primer shall be applied and allowed to dry. All drains shall be covered to at least 6 inches (152 mm) beyond the edges with AFM 500 Detail

Tape. Typical installation details are depicted in Figure 1 of this report.

Ceramic tiles, complying with ANSI A137.1 or dimension stone complying with ASTM C1364, shall then be installed over AFM membranes using latex-modified thinset mortars complying with ANSI A118.10. JS160H Mastic shall cure for 24 hours minimum before tile installation.

3.2.1.2 Application over Plywood and Metal Substrates: AFM membrane is limited to exterior applications only over plywood and No. 20 gage [0.036-inch (0.91 mm)] galvanized sheet metal substrates. The substrates shall be clean and free of all oils, grease, and other contaminants. Substrate surfaces that are dry or dusty shall be dampened and swept off. The ambient and substrate temperatures shall be between 45°F and 120°F (7°C and 49°C).

The Universal Water Based Primer or #80 primer is applied using a brush or roller to the substrate at an application rate of 200 square feet per gallon (4.91 m²/L). The primer shall be allowed to fully dry before the membrane is installed. When fully cured, the primer will be tacky to the touch and will not come off the surface.

The balance of the installation shall comply with Section 3.2.1.1 of this report.

3.2.2 AFM-WM Anti-Fracture Membrane and Jiffy Seal 140/60 Membrane: AFM-WM and Jiffy Seal 140/60 membranes shall be applied over concrete, plywood, and No. 20 gage [0.036-inch (0.91 mm)] galvanized sheet metal substrates similar to those for AFM membranes in Section 3.2.1 of this report, with the exception that the 2-inch (51 mm) peel-and-stick strip (zip-strip) side overlap guide shall be removed prior to application of membrane layers.

4.0 PRODUCT DESCRIPTION

4.1 Product Information: All AFM and AFM-WM Anti-Fracture Membrane materials shall be stored indoors, out of direct sunlight in a dry location. When the membranes are stored at temperatures between 50°F and 90°F (10°C and 32°C), the materials have a shelf life of up to two years. The materials shall remain in the packaging until ready for use.

4.2 AFM Anti-fracture Membrane: AFM Anti-Fracture Membranes (AFM) are self-adhering, 40-mil-thick (1.016 mm) peel-and-stick waterproofing membranes. These membranes contain fabric reinforcement laminated to a SBS modified rubberized asphalt adhesive layer. A release film protects the adhesive surface and shall be removed during installation. The product is available in 12-inch-wide by 25-foot-long, 12-inch-wide by-75-foot-long, and 36-inch-wide by-75-foot-long rolls (304 mm by 7.6 m, 394 mm by 22.8 m, and 914 mm by 22.8 m).

4.3 AFM-WM Anti-Fracture Membranes: AFM-WM Anti-Fracture Membranes are similar to AFM Anti-Fracture



Membranes described in Section 4.2 of this report with an added 2-inch (51 mm) peel-and-stick side-overlap strip that is used as the leading edge for membrane seams. The membrane is available in 36-inch-wide-by-75-foot-long rolls (914 mm by 22.8 m).

4.4 Jiffy Seal 140/60 Membrane: Jiffy Seal 140/60 membranes are self-adhering, 60-mil-thick (1.524 mm), peel-and-stick waterproofing membranes. These membranes are manufactured from a layer of modified rubberized asphalt, reinforced with an inert reinforcement that is sandwiched between two layers of modified rubberized asphalt. The membrane is tacky on both sides and has a release film on the top surface to prevent it from adhering to itself prior to application. The membrane has a 2-inch wide (51 mm) peel-and-stick side-overlap strip and is available in 12-inch-wide by 50-foot-long, 30-inch-wide by 50-foot-long, and 60-inch-wide-by-50-foot-long rolls (304 mm by 15.24 m, 762 mm by 1524 m, and 1524 mm by 15.24 m).

4.5 AFM500 Detail Tape: AFM500 Detail Tape is a 40-mil-thick (1.16 mm) unreinforced tape used for detailing inside corners, drains, posts, protrusions, and any other areas where it is difficult for the membrane to fit in, before membrane installation. The black, SBS modified rubberized asphalt tapes are packaged in either 6-inch-wide by 50-foot-long rolls or 12 inch-wide by 50-foot-long rolls (152 mm by 15.24 m or 304 mm by 15.24 m).

4.6 #6000 Primer: The #6000 Primer is a water-based primer for indoor membrane installations. The primer is mixed before and during application in its full, concentrated strength. Packaged in 16-ounce or one-gallon (0.47 or 3.7 L) containers, the primer shall be stored at a 40°F (4°C) minimum. Maximum shelf life is 12 months in unopened containers.

4.7 Universal Water Based Primer: The Universal Water Based Primer is a water-based primer for indoor and outdoor, horizontal and vertical membrane applications. The primer is mixed before and during application in its full, concentrated strength. Packaged in one-gallon or five-gallon containers (3.7 or 18.93 L), the primer shall be stored at a 40°F (4°C) minimum. Maximum shelf life is 12 months in unopened containers.

4.8 #80 Primer: The #80 Primer is an exterior-grade primer for exterior membrane installations. The primer contains asphalt SBS solvents and is used in its full, concentrated strength. Packaged in one-gallon, five-gallon, or 55-gallon (3.78, 18.93, or 208 L) containers, the primer shall be stored at room temperature. Maximum shelf life is 12 months in unopened containers.

4.9 JS 160H Mastic: JS160H Mastic is a rubberized, adhesive, liquid membrane containing bituminous and synthetic resins used for sealing membrane terminations and, at end laps, for seam sealing and for membrane repairs. The JS160H Mastic shall not be used as a floor-leveling

compound beneath membranes. Packaged in 10.5-ounce, one-gallon, or five-gallon (0.31, 3.78, or 18.93 L) containers, the primer shall be stored at room temperature. Maximum shelf life is 12 months in unopened containers.

5.0 IDENTIFICATION

Rolls of AFM, AFM-WM Anti-Fracture Membrane and Jiffy Seal 140/60 Membrane materials shall bear labels indicating the Protecto Wrap Company name and address, the product name, the date of manufacture, and the IAPMO UES evaluation report number (ER-334).

Containers of AFM 500 Detail Tape, #80 Primer, and #6000 Primer, and Universal Water Based Primer shall bear labels indicating the Protecto Wrap Company name and address, the product name and the date of manufacture.

Either IAPMO UES Mark of Conformity may also be used as shown below:

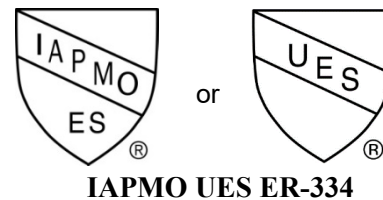

6.0 SUBSTANTIATING DATA

Supporting data was submitted in accordance with ICC-ES AC115, Acceptance Criteria for Waterproof Membranes for Flooring and Shower Liners, dated June 2003 (editorially revised November 2016). Test reports submitted for this report are from laboratories recognized as complying with ISO/IEC 17025.

7.0 STATEMENT OF RECOGNITION

This evaluation report describes the results of research carried out by IAPMO Uniform Evaluation Service on Protecto Wrap Company's AFM and AFM-WM Anti-Fracture Membranes and Jiffy Seal 140/60 Waterproofing Membranes to assess conformance to the codes shown in Section 1.0 of this report and serves as documentation of the product certification. Products are manufactured as noted in Section 2.5 of this report under a quality control program with periodic inspection under the supervision of IAPMO UES.

For additional information about this evaluation report please visit www.uniform-es.org or email us at info@uniform-es.org



FRONT VIEW #1

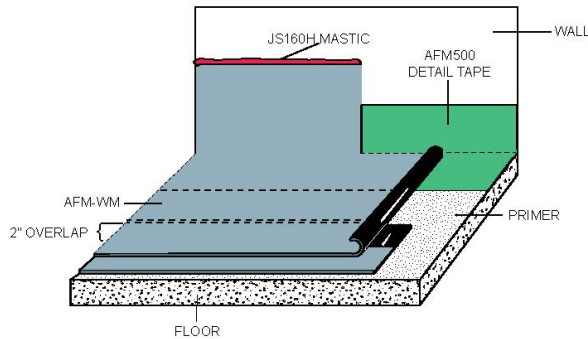

FRONT VIEW #2

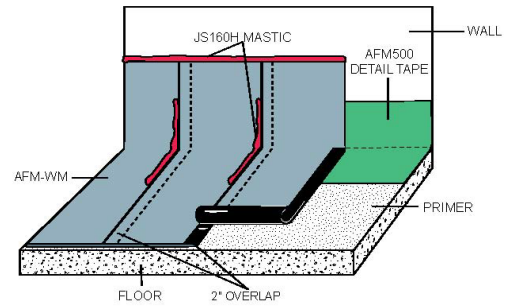

INSIDE CORNER (SIDE VIEW)

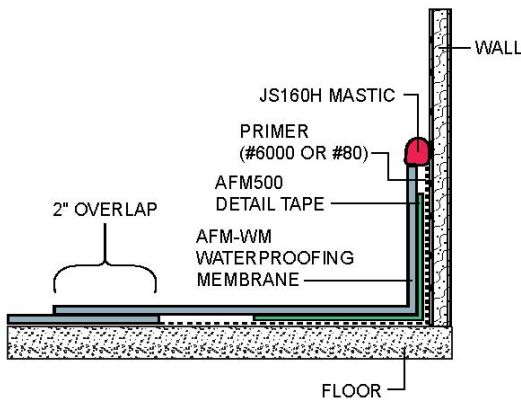

DRAIN DETAIL

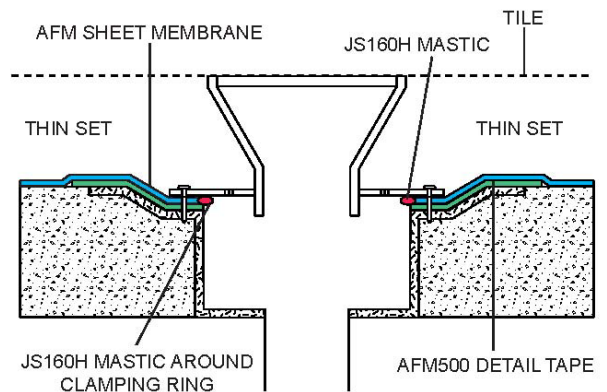

END LAP/T-JOINT

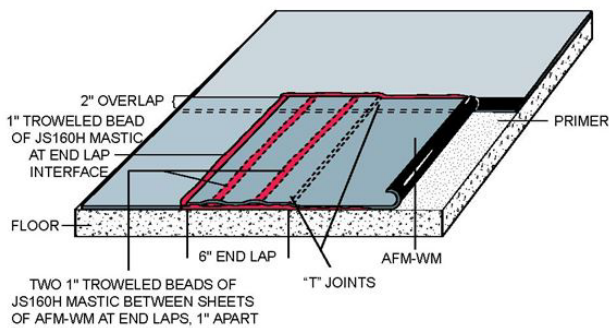

POST & PROTRUSION

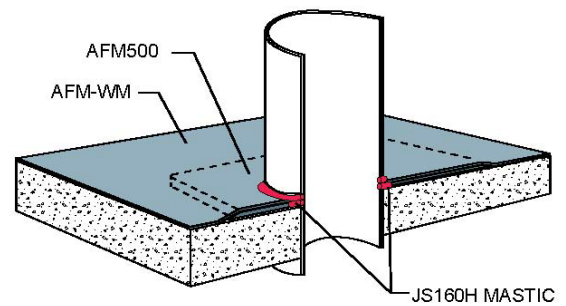



CALIFORNIA SUPPLEMENT

PROTECTO WRAP COMPANY

1955 South Cherokee Street

Denver, Colorado 80223

(800)759-9727

www.protectowrap.com

AFM AND AFM-WM ANTI-FRACTURE MEMBRANES AND JIFFY SEAL 140/60 WATERPROOFING MEMBRANES

CSI Section:

09 30 00—Tiling

1.0 RECOGNITION

The Protecto Wrap Company AFM and AFM Anti-Fracture Membranes and Jiffy Seal 140/60 Waterproofing Membranes, as evaluated and represented in IAPMO UES Evaluation Report ER-334 and with additions as noted in this supplement, are satisfactory alternatives for use in buildings built under the following codes (and regulations):

- 2019 and 2016 California Building Code (CBC)
- 2019 and 2016 California Residential Code (CRC)
- 2019 and 2016 California Plumbing Code (CPC)

2.0 LIMITATIONS

Use of the Protecto Wrap Company AFM and AFM Anti-Fracture Membranes and Jiffy Seal 140/60 Waterproofing Membranes recognized in this report is subject to the following limitations:

- 2.1 Each roll shall be identified by the manufacturer's name and trade name of the product.
- 2.2 None of the products shall be used where a fire-retardant roof covering is required.
- 2.3 The product shall not be used to seal peripheries of plastic pipe or conduits or to seal penetrations of fire-rated wall and floors.
- 2.4 Installation of the product shall be in accordance with the manufacturer's instructions and the requirements herein. A copy of this report and the installation instructions shall be provided at each job site by the manufacturer.
- 2.5 Membranes shall be applied on primed surfaces only. Protecto Wrap No. 80 Primer shall be used at the rate of 100 to 300 square feet per gallon. Primed surfaces must be covered with the membrane on the same day applied or be reprimed.

2.6 Sheet membrane side laps shall be a minimum of 2 inches and end laps shall be a minimum of 4 inches.

2.7 Area around all protrusions shall be coated with Jiffy Seal 160H Mastic before and after application of the membrane.

2.8 This supplement expires concurrently with ER-334.

3.0 PRODUCT USE

AFM and AFM-WM Anti-Fracture Membranes are waterproofing membranes used as nonmetallic shower linings complying with the additional requirements and testing of the completed shower liner installation as set forth with Section 408.7 of the UPC and Section 411.8 of the CPC, Title 24, Part 5.

For additional information about this evaluation report please visit www.uniform-es.org or email us at info@uniform-es.org



CITY OF LOS ANGELES SUPPLEMENT

PROTECTO WRAP COMPANY
1955 South Cherokee Street
Denver, Colorado 80223
(800)759-9727
www.protectowrap.com

AFM AND AFM-WM ANTI-FRACTURE MEMBRANES AND JIFFY SEAL 140/60 WATERPROOFING MEMBRANES

CSI Section:
09 30 00—Tiling

1.0 RECOGNITION

The Protecto Wrap Company's AFM and AFM Anti-Fracture Membranes and Jiffy Seal 140/60 Waterproofing Membranes, as evaluated and represented in IAPMO UES Evaluation Report ER-334 and with additions as noted in this supplement, are satisfactory alternatives for use in buildings built under the following codes (and regulations):

- 2020 and 2017 City of Los Angeles Building Code (LABC)
- 2020 and 2017 City of Los Angeles Residential Code (LARC)

2.0 LIMITATIONS

Use of the Protecto Wrap Company AFM and AFM Anti-Fracture Membranes and Jiffy Seal 140/60 Waterproofing Membranes recognized in this report is subject to the following limitations:

- 2.1** Each roll shall be identified by the manufacturer's name and trade name of the product.
- 2.2** None of the products shall be used where a fire-retardant roof covering is required.
- 2.3** The product shall not be used to seal peripheries of plastic pipe or conduits or to seal penetrations of fire-rated wall and floors.
- 2.4** Installation of the product shall be in accordance with the manufacturer's instructions and the requirements herein. A copy of this report and the installation instructions shall be provided at each job site by the manufacturer.
- 2.5** Membranes shall be applied on primed surfaces only. Protecto Wrap No. 80 Primer shall be used at the rate of 100 to 300 square feet per gallon. Primed surfaces must be

covered with the membrane on the same day applied or be reprimed.

2.6 Sheet membrane side laps shall be a minimum of 2 inches and end laps shall be a minimum of 4 inches.

2.7 Area around all protrusions shall be coated with Jiffy Seal 160H Mastic before and after application of the membrane.

2.8 This supplement expires concurrently with ER-334.

3.0 PRODUCT USE

AFM and AFM-WM Anti-Fracture Membranes are waterproofing membranes used as nonmetallic shower linings complying with the additional requirements and testing of the completed shower liner installation as set forth with Section 408.7 of the UPC and Section 411.8 of the CPC, Title 24, Part 5.

For additional information about this evaluation report please visit www.uniform-es.org or email us at info@uniform-es.org



FLORIDA SUPPLEMENT

PROTECTO WRAP COMPANY

1955 South Cherokee Street

Denver, Colorado 80223

(800)759-9727

www.protectowrap.com

AFM AND AFM-WM ANTI-FRACTURE MEMBRANES AND JIFFY SEAL 140/60 WATERPROOFING MEMBRANES

CSI Section:

09 30 00—Tiling

1.0 RECOGNITION

The Protecto Wrap Company's AFM and AFM Anti-Fracture Membranes and Jiffy Seal 140/60 Waterproofing Membranes, as evaluated and represented in IAPMO UES Evaluation Report ER-334 and with additions as noted in this supplement, are satisfactory alternatives for use in buildings built under the following codes (and regulations):

- 2020 Florida Building Code, Building (FBC, Building)
- 2020 Florida Building Code, Residential (FBC, Residential)
- 2020 Florida Building Code, Plumbing (FBC, Plumbing)

2.0 LIMITATIONS

Use of the Protecto Wrap Company AFM and AFM Anti-Fracture Membranes and Jiffy Seal 140/60 Waterproofing Membranes recognized in this report is subject to the following limitations:

2.1 AFM and AFM-WM Anti-Fracture Membranes and Jiffy Seal 140/60 Membranes have not been evaluated for compliance with the High-Velocity Hurricane Zone provisions of the 2020 and 2017 Florida Building Code, Building; Florida Building Code, Residential; and Florida Building Code, Plumbing, as applicable, and is outside the scope of this report.

2.2 For products falling under Section (5)(d) of Florida Rule 61G20-3.008, verification that the report holder's quality assurance program is audited by a quality assurance entity approved by the Florida Building Commission (or the building official when the report holder does not possess an approval by the Commission), to provide oversight and determine that the products are being manufactured as described in this evaluation report to establish continual product performance.

2.3 This supplement expires concurrently with ER-334.

3.0 PRODUCT USE

AFM and AFM-WM Anti-Fracture Membranes are waterproofing membranes used as shower linings in accordance with Section P2702.2 of the Florida Building Code, Residential or Section 417.5 of the Florida Building Code, Plumbing.

For additional information about this evaluation report please visit www.uniform-es.org or email us at info@uniform-es.org